

15" BCD Auger Base

Auger Bases (Screw-in Bases) are used as foundations for street, site and parking light poles. Auger bases are installed with hydraulic rotary equipment that turns the base into the ground with the assistance of a helix shaped plate.

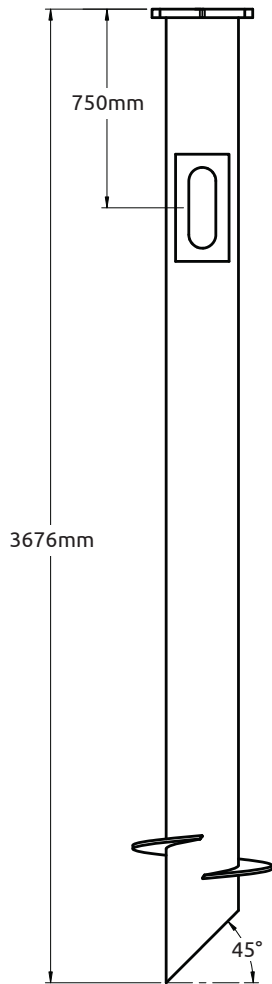

104-04-7A1215-F

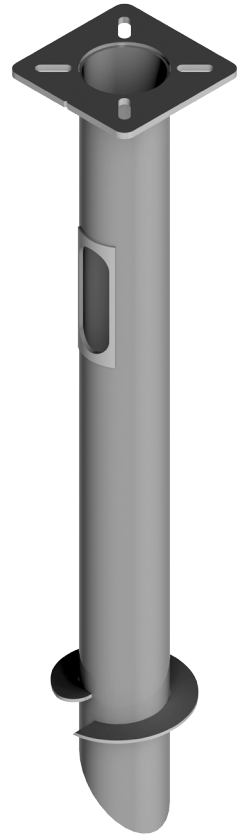
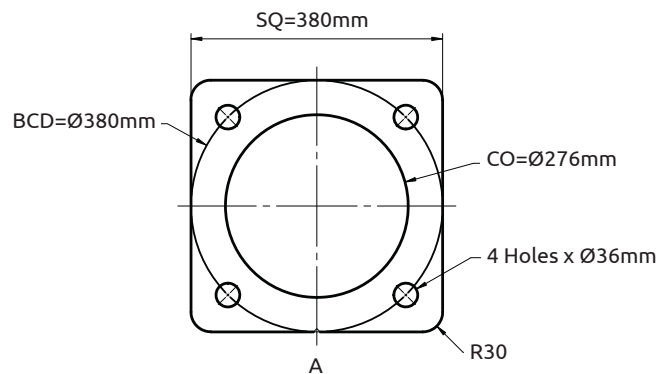

Qty	Part No.	Description	Material	Unit Weight	Total Weight
4	H70-F436-G1.250	Washer, Flat, Structural, Galv.	ASTM F436	0.1	0.4
4	H10-A325-1.250X4.00	Bolt Hex, Galv.	ASTM A325 Type 1	1.0	4.0
4	H40-A194-G1.250	Nut, Heavy Hex, Galv.	ASTM A194 Gr. 2H	0.4	1.6
Fasteners Weight (kg) =				6	
Product Weight (kg) =				261.11	
Total Weight (kg) =				287.11	